

DRAWING NO.

C340TSX

REV

T

## Customer Drawing

## Revision History

| REV | DESCRIPTION (ECO)                                    | DATE     | APPROVED |
|-----|--|----------|----------|
| S   | UPDATE MAT. CALLOUT FOR PB, PR, PW SUFFIX'S ECO 5404 | 10/01/12 | AK       |
| T   | REV UPDATED TO "T" REV. ECO 5912                     | 11/21/13 | AK       |

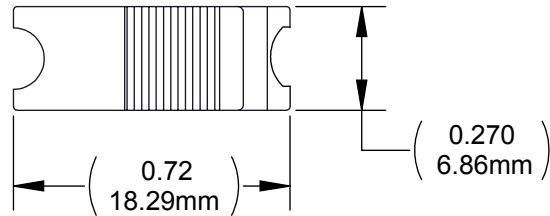

0.0-.020  
(0.0- 0.51mm)  
CLOSED POSITION

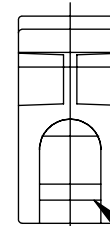
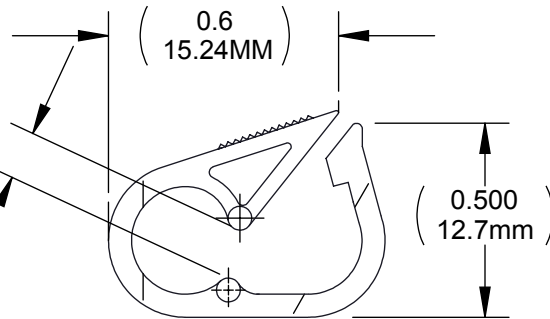

SEE NOTE 5.

## NOTES:

## 1. SUFFIX INDICATES MATERIAL &amp; COLOR:

| CELCON        | POLYPROPYLENE |
|---------------|---------------|
| B - " BLUE    | PB - " BLUE   |
| N - " NATURAL | PR - " RED    |
| R - " RED     | PW - " WHITE  |
| PL - " PURPLE |               |
| YL - " YELLOW |               |
| CR - " CREAM  |               |
| BK - " BLACK  |               |

- CRITICAL DIMENSIONS ARE CIRCLED AND SUBJECT TO INSPECTION.
- DIMENSIONS IN PARENTHESES ARE FOR REFERENCE ONLY.
- ALL DIMENSIONS ARE IN INCHES WITH NOMINAL IN MILLIMETERS BELOW.
- MAX TUBING DIA. (0.16").

6. HR TUBING CLAMPS ARE SINGLE PATIENT USE MEDICAL COMPONENTS INTENDED TO BE INCLUDED AS PART OF THE FINISHED DEVICE, I.E. IV ADMINISTRATION SETS. HR TUBING CLAMPS ARE MANUFACTURED TO HR SPECIFICATIONS, SOLD BULK, NON-STERILE TO OEMS. BECAUSE THE CONFIGURATIONS OF IV TUBING VARY DRAMATICALLY, HR CANNOT MAKE ANY PARTICULAR CLAIMS. CUSTOMERS MUST VALIDATE CLAMPS FOR THEIR INTENDED USE, ENSURING THAT THE CLAMPS EFFECTIVELY OCCLUDE THE INHERENT VARIATION OF THE PARTICULAR TUBING EMPLOYED BY THE CUSTOMER AGAINST THE CLOSED GAP RANGE PROVIDED ON HR'S SPECIFICATIONS. OEM MANUFACTURING PROCESSES (SUCH AS ASSEMBLY PROCESSES, PACKAGING AND STERILIZATION) CAN SIGNIFICANTLY ALTER THE CLAMPS' FUNCTIONALITY; THEREFORE, HR CANNOT GUARANTEE THE PERFORMANCE OF THE FINAL CONFIGURATION.

## QUALITY CRITERIA

O.D. FLASH 0.015 MAX. (0.4MM)

GATE VESTIGE 0.01 MAX. (0.3MM)

EMBEDDED PARTICLES, BUBBLES, SPOTS, STAINS: 0.3mm<sup>2</sup> MAX. NO MORE THAN 5 PER PART.

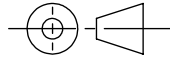
|                                    |   |             |          |   |                             |            |             |
|------------------------------------|---|-------------|----------|---|-----------------------------|------------|-------------|
| <b>DRAWN BY</b>                    | M.S.  | <b>DATE</b> | -        |  <b>Halkey-Roberts</b> |                             |            |             |
| <b>APPROVED BY</b>                 | J.W.  | <b>DATE</b> | 04/04/96 |   |                             |            |             |
| <b>MATERIAL</b>                    | SEE NOTES   |             |          |   |                             |            |             |
| <b>FINISH</b>                      |   |             |          | <b>TITLE</b>  | <b>TUBING CLAMP, MICRO</b>  |            |             |
| <b>UNLESS OTHERWISE SPECIFIED:</b> | <b>THIRD ANGLE PROJECTION</b>   |             |          | <b>SIZE</b>   | <b>DRAWING NO.</b>          |            |             |
| DIMENSIONS ARE IN INCHES           |  |             |          | <b>A</b>  | <b>C340TSX</b>              |            |             |
| TOLERANCES:                        |   |             |          | <b>SCALE</b>  | <b>DO NOT SCALE DRAWING</b> | <b>REV</b> | <b>T</b>    |
| ANGULAR: ± 1°                      |   |             |          | <b>2:1</b>  | <b>SHEET</b>                | <b>1</b>   | <b>OF 2</b> |
| TWO PLACE DECIMAL ± .01            |   |             |          |   |                             |            |             |
| THREE PLACE DECIMAL ± .005         |   |             |          |   |                             |            |             |

## MOLDED PARTS:

GATES, PARTING LINES, AND FLASH PER QUALITY CRITERIA

## PROPRIETARY AND CONFIDENTIAL

THE INFORMATION CONTAINED IN THIS DRAWING IS THE SOLE PROPERTY OF HALKEY-ROBERTS CORPORATION ST. PETERSBURG, FL. ANY REPRODUCTION IN PART OR AS A WHOLE WITHOUT THE WRITTEN PERMISSION OF HALKEY-ROBERTS CORPORATION IS PROHIBITED.